

Peltier Application Note

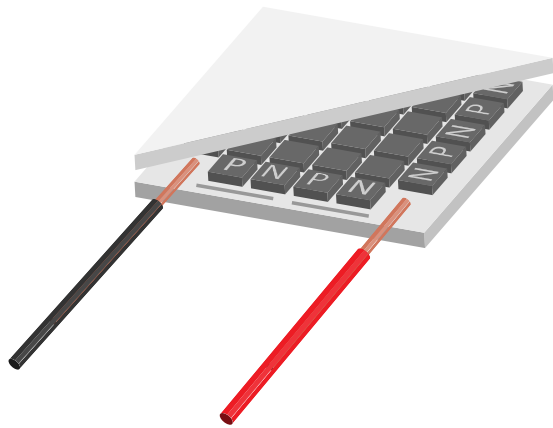

Early 19th century scientists, Thomas Seebeck and Jean Peltier, first discovered the phenomena that are the basis for today's thermoelectric industry. Seebeck found that if you placed a temperature gradient across the junctions of two dissimilar conductors, electrical current would flow. Peltier, on the other hand, learned that passing current through two dissimilar electrical conductors, caused heat to be either emitted or absorbed at the junction of the materials. It was only after mid-20th Century advancements in semiconductor technology, however, that practical applications for thermoelectric devices became feasible. With modern techniques, we can now produce thermoelectric "modules" that deliver efficient solid state heat-pumping for both cooling and heating; many of these units can also be used to generate DC power at reduced efficiency. New and often elegant uses for thermoelectrics continue to be developed each day.

PELTIER STRUCTURE

A typical thermoelectric module consists of an array of Bismuth Telluride semiconductor pellets that have been "doped" so that one type of charge carrier—either positive or negative—carries the majority of current. The pairs of P/N pellets are configured so that they are connected electrically in series, but thermally in parallel. Metalized ceramic substrates provide the platform for the pellets and the small conductive tabs that connect them.

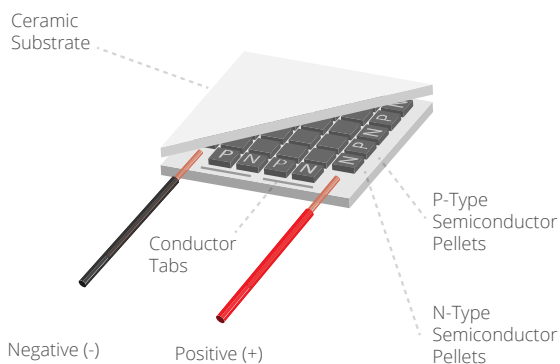

FIGURE 1. CONSTRUCTION

PELTIER THEORY

When DC voltage is applied to the module, the positive and negative charge carriers in the pellet array absorb heat energy from one substrate surface and release it to the substrate at the opposite side. The surface where heat energy is absorbed becomes cold; the opposite surface where heat energy is released, becomes hot. Reversing the polarity will result in reversed hot and cold sides.

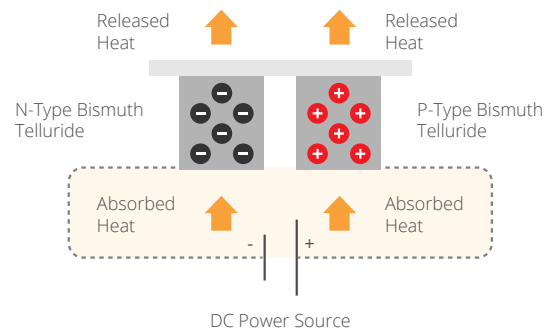

FIGURE 2. THEORY

HOW TO READ THE TECHNICAL DATA

REGARDING PELTIER MODULE SPECIFICATIONS

The maximum electric current [I_{max}] and the maximum voltage [V_{max}] values are not the absolute maximum rated values. Instead, considering performance coefficients and heat radiation design, it is recommended that products are used to around 70% of the maximum electric current and voltage values. If products are used with voltages and currents which exceed the maximum values, heat absorption will decrease and Joule heating will increase. As a result, not only will efficiency be reduced, but the increase in temperature will have an adverse effect on the soldering connecting the semiconductor and could lead to a break down and reverse diffusion.

REGARDING PELTIER MODULE FUNCTION DIAGRAMS

The maximum temperature difference [ΔT_{max}] is the temperature difference between the sides of the semiconductor when the heat absorption is 0[W]. Also, the maximum heat absorption, Q_{max} , is attained when the temperature difference between the sides of the semiconductor is 0. Even though these are both not actual values but theoretical figures, please use these as a guide for choosing modules.

For the relationship between electric current, voltage, temperature difference and heat absorption, please consult the function diagrams in the design examples.

DESIGN EXAMPLES

EXAMPLE 1 [CP60440]

What is the heat absorption [Qc] and supplied current [I] when Th=50°C, Tc=10°C, Voltage=12 Vdc?

- 1) Find ΔT
 $\Delta T = T_h - T_c$
 $= 50 - 10 = 40^\circ\text{C}$
- 2) Find the supplied voltage from the function diagram
 From the diagram, at $T_h = 50^\circ\text{C}$ $I = 3.77\text{ A}$
- 3) Find the heat absorption [Qc] from the function diagram
 The current found in [2] is 3.77 A, so from the diagram at $T_h = 50^\circ\text{C}$ $Q_c = 20.75\text{ W}$

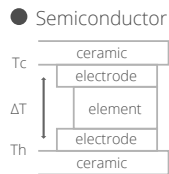
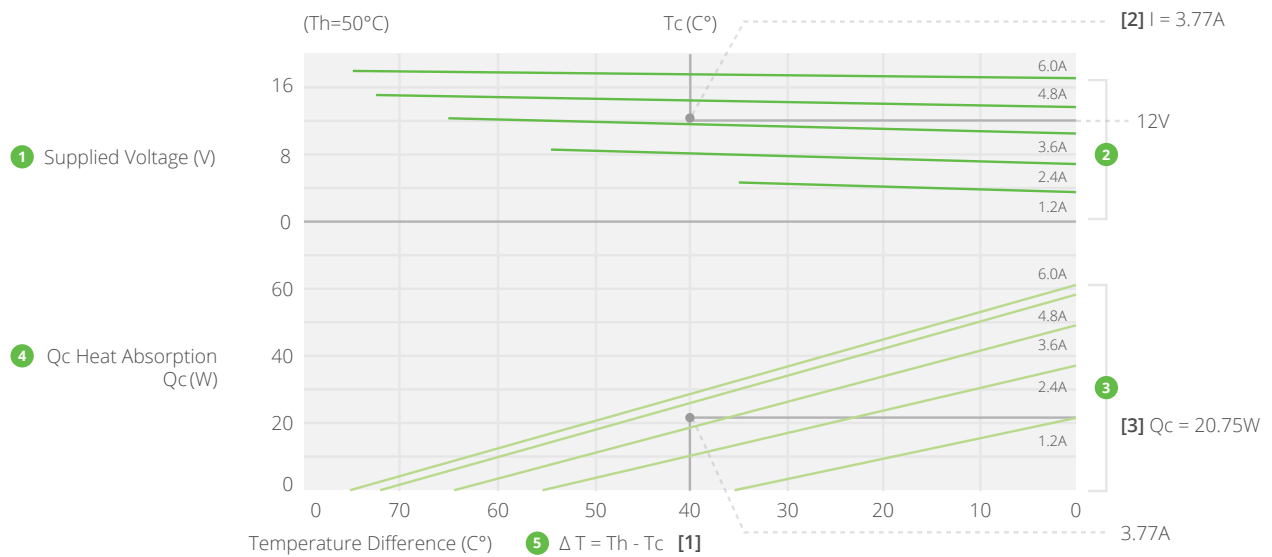

FIGURE 3. FUNCTION DIAGRAM

- 1) Potential difference across the Peltier Module [V].
- 2) The connection between ΔT [°C] for each supplied current and voltage [V].
- 3) The connection between ΔT [°C] for each supplied current and heat absorption [W].
- 4) Heat absorption of the Peltier Module [W].
- 5) The temperature difference [ΔT] shows the difference between the hot side and cool side of the peltier module and the electrodes. It is not the difference between the cool side and the background temperature.

EXAMPLE 2

How to choose a cooler unit

When choosing a cooler unit that suits the functions you require, you need to know the heat absorption rate and temperature difference. These two things can be calculated easily.

Example of heat calculation when cooling in an enclosed environment

<i>Conditions:</i>	<i>Internal dimensions of box</i>	500 • 200 • 100 [mm] 10 liters
	<i>External dimensions</i>	560 • 260 • 160 [mm]
	<i>Thermal insulation</i>	30 [mm] urethane foam
	<i>Internal temperature</i>	5°C
	<i>Ambient temperature</i>	30°C

1) Thermal conductivity λ

$\lambda = 0.025$ [W/m°C]: Thermal conductivity of urethane foam

$t = 0.03$ [m]: Thickness of thermal insulation

2) Surface area of box [at center of thermal insulation] S

$$S = [0.53 \cdot 0.23] \cdot 2 + [0.23 \cdot 0.13] \cdot 2 + [0.53 \cdot 0.13] \cdot 2 = 0.44 \text{ [m}^2\text{]}$$

3) Overall heat transfer rate K

Thermal conductivity of external surface: $h1 = 20$ [W/m²°C]

Thermal conductivity of internal surface: $h2 = 10$ [W/m²°C]

$$\begin{aligned} K &= 1 / \{ [1/h1] + [1/h2] + t/\lambda \} \\ &= 1 / \{ [1/20] + [1/10] + 0.03/0.025 \} \\ &= 0.74 \text{ [W/m}^2\text{°C]} \end{aligned}$$

4) Amount of heat entering the insulated box from external sources $Q1$

$$\begin{aligned} Q1 &= S \cdot K \cdot \Delta T \\ &= 0.44 \cdot 0.74 \cdot [30-5] \\ &= 8.1 \text{ W} \end{aligned}$$

5) Necessary heat absorption Q

Internal thermal loading [in the case of loading from an internal heat source]: Let $Q2 = 5$ [W]

$$Q = Q1 + Q2 = 13.1 \text{ [W]}$$

6) Choice of cooler unit

Adding a safety margin of 25% to the necessary heat absorption give 16.4 [W]. In other words, a cooler unit that provides heat absorption of over 16 [W] and a temperature difference of at least 25° is necessary.

Ex. CP30238 can easily give a 30° difference at 6 W of heat absorption, so 16.4 W / 6 W means roughly three units are necessary.

EXAMPLE 3

Example of heat calculation when cooling in an enclosed environment

<i>Conditions:</i>	<i>Internal dimensions of box</i>	250 • 200 • 100 [mm] 5 liters
	<i>External dimensions</i>	310 • 260 • 160 [mm]
	<i>Thermal insulation</i>	30 [mm] urethane foam
	<i>Cooling time</i>	1 hour
	<i>Initial water temperature</i>	20°C
	<i>Cooled temperature</i>	10°C
	<i>Ambient temperature</i>	30°C

1) Thermal conductivity λ

$\lambda = 0.025$ [W/m°C]: Thermal conductivity of urethane foam

$t = 0.03$ [m]: Thickness of thermal insulation

2) Surface area of box [at center of thermal insulation] S

$$S = [0.28 \cdot 0.23] \cdot 2 + [0.23 \cdot 0.13] \cdot 2 + [0.28 \cdot 0.13] \cdot 2 = 0.26 \text{ [m}^2\text{]}$$

3) Overall heat transfer rate K

Thermal conductivity of external surface: $h1 = 20$ [W/m²°C]

Thermal conductivity of internal surface: $h2 = 200$ [W/m²°C]

$$\begin{aligned} K &= 1 / \{ [1/h1] + [1/h2] + t/\lambda \} \\ &= 1 / \{ [1/20] + [1/200] + 0.03/0.025 \} \\ &= 0.8 \text{ [W/m}^2\text{°C]} \end{aligned}$$

4) Amount of heat entering the insulated box from external sources Q1

$$\begin{aligned} Q1 &= S \cdot K \cdot \Delta T \\ &= 0.26 \cdot 0.8 \cdot [30-10] \\ &= 4.2 \text{ W} \end{aligned}$$

5) Necessary heat absorption to cool water Q2

C_p : specific heat capacity of water [Kcal / Kg•°C]

p : specific density of water [Kg / L]

v : volume of water [L]

$$\begin{aligned} Q2 &= C_p \cdot p \cdot v \cdot \Delta T \\ &= 1 \cdot 1 \cdot 5 \cdot [20-10] \\ &= 50 \text{ Kcal} \end{aligned}$$

In other words, to cool the water in one hour.

$$\begin{aligned} Q2 &= 50,000 \text{ cal} \cdot 4.19 \text{ J} / 3600 \text{ sec} = 58.2 \text{ [W]} \\ [1 \text{ cal} &= 4.19 \text{ J}; 1 \text{ J} / \text{s} = 1 \text{ W}] \end{aligned}$$

6) Necessary heat absorption Q

There is no thermal loading from the water. Therefore, $Q3 = 0$

$$\begin{aligned} Q &= Q1 + Q2 + Q3 \\ &= 4.2 + 58.2 + 0 = 62.4 \text{ [W]} \end{aligned}$$

7) Choice of cooler unit

Adding a safety margin of 25% to the necessary heat absorption give 78.0 [W]. In other words, a cooler unit that provides heat absorption of over 78 [W] and a temperature difference of at least 20° is necessary.

Ex. CP60333 can easily give a 25° difference at 16 W of heat absorption, so 78.0 W / 16 W means roughly five units are necessary. However, since the heat absorption calculations include the heat capacity of water, in actuality a smaller number of units would perform the task [because the heat absorption is greater under powered conditions].

MOUNTING METHOD

USING PELTIER MODULES

When a direct current is passed through a Peltier Module, the low temperature side absorbs heat and the high temperature side emits heat, so that a temperature difference exists across the surfaces. However, since the heat emitted is more reactive to the amount of electricity input into the module than the heat absorbed, if a direct current is continuously passed through the module the emitted heat will exceed the absorbed heat and both sides of the unit will become hot. For that reason, it is necessary to connect the module to a radiator such as aluminum fins to efficiently disperse the emitted heat. A Peltier Module fitted between a radiator and a heat extractor like an aluminum block for use as a cooling device is called a Cooler Unit

ASSEMBLING A COOLER UNIT

1) Wipe the surface of the radiator fins to be attached to the Peltier Module free of dirt and grease using alcohol or similar and thinly spread thermally-conductive silicon grease on the appropriate area.

2) In the same way, wipe the heat emitting side of the Peltier Module with alcohol or similar and thinly spread with thermally-conductive silicon grease. At this point, take care that nothing is attached to the unit.

3) Place the heat-emitting side of the Peltier Module onto the appropriate place on the radiator fins. While applying light pressure to the unit, slide the unit back and forth, left and right, approximately 20 times to ensure a good fit and to lose any layer of air between the connecting sides. **[figure 4]**

4) Wipe the heat absorbing side of the Peltier Module free of dirt and grease with alcohol or similar and thinly apply thermally-conductive silicon grease.

5) In the same way, wipe the surface of the aluminum block to be attached to the Peltier Module with alcohol or similar and thinly apply thermally-conductive silicon grease.

6) Place the aluminum block onto the heat absorbing side of the Peltier Module. Once again, apply light pressure to the block and slide it back and forth, left and right, to ensure a tight fit and lose any layer of air between the connecting sides. **[figure 5]**

7) Check that the holes in the aluminum block are in line with the screw holes in the radiator fins. Put one of each type of washer (in the order: spring washer, flat washer, silicon washer) onto the fixing screws [SUS], apply liquid thread lock and then put the screws into the holes.

8) Tighten the screws until the washers are gently held in place. While doing this, to ensure that even force is applied across the module, apply 200 ~ 300 N [for a 40 mm square unit] of pressure to the center of the aluminum block and tighten each of the screws alternately little by little. **[figure 6]**

9) When the module is gently secured, tighten the screws alternately in the same manner as in step 8 to a torque of 10 N · cm. Continue tightening to a final torque of 20 ~ 30 N · cm [M3-M4]. When tightening the screws, take care to avoid unbalanced stress to the unit.

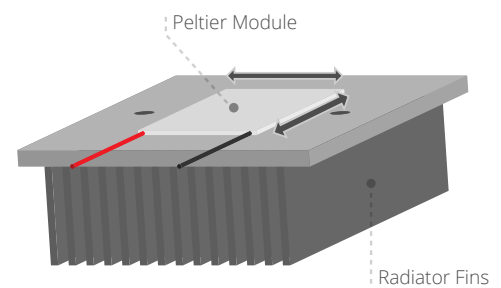

FIGURE 4. INSTALLING THE PELTIER MODULE

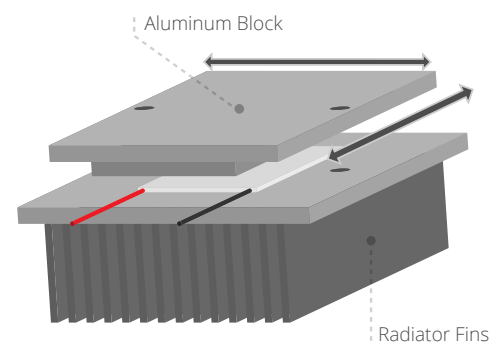

FIGURE 5. INSTALLING THE ALUMINUM BLOCK

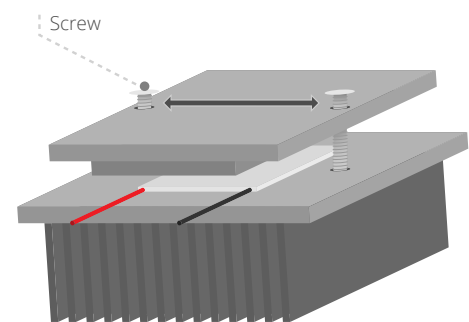

FIGURE 6. ORDER OF SCREW TIGHTENING

Peltier Application Note

10] When the screws are tightened to the above torque, let the unit stand for 30 ~ 60 minutes and then once again check the screw tightening torque. Also, wipe away any excess silicon grease. When M4 is tightened to 10 N · cm, approximately 100 N of axial tension is being applied. For a single 40 mm square module, tightening to 200 ~ 300 N of axial tension is a sufficient load.

11] As a protection against humidity, seal the perimeter of the Peltier Module with a silicon sealant or similar and allow to dry for the requisite time. [figure 7]

12] When the above process is complete, measure the resistance value of the unit to check for abnormalities. The resistance value cannot be measured with a normal tester. An A/C 4 probe resistance gauge must be used. [ex. Tsuruga Electric model no. 3566]

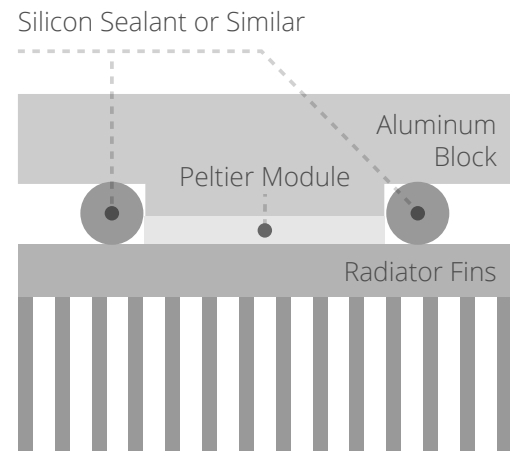

FIGURE 7. HUMIDITY PROTECTION FOR THE PELTIER MODULE PERIMETER

MOUNTING GUIDELINES

While building peltier modules into your cooling unit, please be cautious with regard to the following:

- 1] Ensure that the peltier module has full surface contact with the heat exchanger. Ideally, deviation from flatness should be kept under 0.02 mm.
- 2] Thinly spread thermally conductive grease between the peltier module surface and the heat exchanger.
- 3] Be sure to apply proper materials for protecting the peltier module from moisture, such as silicone and epoxy.
- 4] Optimum efficiency is not obtained at maximum voltage or maximum electric current. It is recommended that the voltage and current are set to about 70% of their maximum.
- 5] Changing the current polarity rapidly as a method of modulation will shorten the life of the unit. Please avoid this method of use.

GENERAL CAUTIONS

Precautions for use:

- 1] Do not allow the Th-side of the peltier module to exceed 80°C or 90°C on other modules.
- 2] Dropping or exerting mechanical shock on the unit can cause it to break. Please take care in the handling of the product.
- 3] Please make sure not to store the peltier module in high humidity or with direct exposure to sunlight. Also avoid exposure to dew or condensation. The appropriate temperature and humidity for storage is 5~35°C and 20~75% RH.

HEAT TRANSFER FORMULA

1] Heat gained or lost through walls

$$Q = [A \cdot \Delta T \cdot K] / (\Delta X)$$

Where:

Q = Heat [Watts]

A = External surface area of container [m²]

ΔT = Temperature difference [inside vs. outside of container] [Kelvin]

K = Thermal conductivity of insulation [Watt / meter Kelvin]

ΔX = Insulation thickness [m]

2] Time required to change the temperature of an object

$$t = [m \cdot C_p \cdot \Delta T] / Q$$

Where:

t = Time interval [seconds]

m = Weight of the object [kg]

C_p = Specific heat of material [J / [kg K]]

ΔT = Temperature change of object [Kelvin]

Q = Heat added or removed [Watts]

Note: It should be remembered that thermoelectric devices do not add or remove heat at a constant rate when ΔT is changing.

An approximation for average Q is: $Q_{ave} = [Q [\Delta T_{max}] + Q [\Delta T_{min}]] / 2$

3] Heat transferred to or from a surface by convection

$$Q = h \cdot A \cdot \Delta T$$

Where:

Q = Heat [Watts]

h = Heat transfer coefficient [W / [m² K]], 1 ~ 30 = "Free" convection - gasses, 10 ~ 100 = "Forced" convection - gasses

A = Exposed surface area [m²]

ΔT = Surface temperature - Ambient [Kelvin]

THEMAL CONDUCTIVITY OF SOME COMMON MATERIALS [W/m-K]

Material	27 °C	50 °C
Pure Copper	401	399
Pure Aluminum	237	238
Aluminum Alloy 2024-T6	177	179
Aluminum Alloy 195	168	169
Brass	110	116
Bronze	54	57
Pure Nickel	91	87
Solder [Tin/Lead]	47	44
Lead-Free Solder [80%Au, 20%Sn]	57	55
Air	0.0263	0.0285
Water	0.613	0.645